

TEM2Go product description and detailed specifications

Table of Contents

1.	Introduction to TEM2Go	1
2.	The instrument	2
3.	Comparing TEM2Go and ERT	3
4.	Extended support and instrument.....	5
	Extended support	5
	App premium functionality	5
5.	External processing software.....	5
6.	Document change log	5
7.	Detailed specifications	6
	Definitions and abbreviations	6
	Transmitter platform	6
	Receiver platform	6
	Transmitter Coil	7
	Receiver Coil	7
	Battery charging suitcase	7
	Backpack carrier system	7
	Weight and dimensions for transport	7

1. Introduction to TEM2Go

The TEM2Go system maps subsurface geological layers, making it an ideal instrument for various land surveying applications such as hydrogeology, geotechnical soil investigation, and mining. With its small and lightweight transmitter and receiver systems mounted on professional ergonomic backpacks, even the most inaccessible terrains can be surveyed; if a field technician can walk there, it can be surveyed.

The depth of investigation is from the surface to a depth of 50 – 100 m, depending on configuration and overall resistivity of the ground. Data is measured continuously, and with Premium functionality enabled, advanced processing and inversion algorithms make it possible to see geological structures instantaneously in the TEMcompany iOS/Android app. The typical working distance between the transmitter and the receiver is 15 – 20 m. The distance, the high precision GPS position and altitude of the transmitter and receiver are automatically measured and saved with the data.

The system shown in Figure 1, is lightweight and extremely easy to use. It is designed so it only takes a few minutes to mount the two small batteries in the transmitter and receiver, power them up, put the backpacks on, open the app on a smartphone, start the instrument and walk. Measured data and subsurface models are displayed in the app in real time.

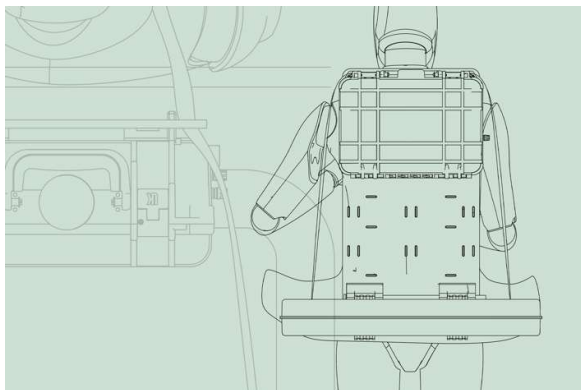



Figure 1. The sketch shows the TEM2Go system. The transmitter is in front while the receiver is at the back. The distance between the coils is a minimum of 15 m.

Typical applications for TEM2Go within hydrogeology are applications such as the characterization of basins for managed aquifer recharge, mapping of peat layers, characterization of shallow aquifers etc. Within the engineering disciplines it is mapping of constructions sites, road traces, excess water infiltration sites and levees. In the mining sector typical applications are mapping of shallow mineralization, geological structures and monitoring of tailing dams. Landfills and point source contamination is another application where TEM2Go can, in a very short time provide an overview of the geological structures and enlighten possible pathways of effluents.

At TEMcompany, we are committed to providing comprehensive support to our customers. We engage in close dialogue to assist with survey planning, help with data quality control, and even aid in interpreting results. Our team of experts is always available to offer guidance and expertise, ensuring that the TEM2Go instrument provides maximum value.



Figure 2. The TEM2Go system in operation.

2. The instrument

Despite the small transmitter and receiver coils, the TEM2Go system has a depth of investigation (DOI) of 50 – 100 m. This large DOI for a system with the very small transmitter coil of only 65 cm 65 cm is obtained by some unique features.

Thin layers close to the surface are resolved because the receiver coil has an impressive bandwidth of close to 350 kHz with a receiver area of 22 m² and a fast transmitter turn-off at around 4 us. The deep layers are resolved because of a high signal/noise (S/N) ratio from the large area of the receiver coil, the large stack size obtained by the ultra-fast repetition of the transients and continuous data sampling while walking. In addition, the system uses intelligent data stacking and tapered gating which further enhances noise suppression.

Data is measured continuously but averaged into soundings, typically at every 10 m. As the system has no bias response or leaking currents in the transmitter, data does not have any correction applied to them during stacking. Noises from the movement of the receiver coils in the earth's magnetic field are suppressed by the ultra-fast sampling at both the high and the low transmitter moments, and in the rare case of a too fast movement of the coils, any remaining effect is suppressed by applying a low pass filter during data stacking.

The transmitter and receiver communicate using mesh Wi-Fi.

Key parameters for the TEM2Go system are shown in Table 1.

Property	Value
Depth of investigation	50 – 100 m
Nominal sounding distance	10 m
Operation mode: Dual Moment	Low moment: 1 Amp High moment: 10 Amp
First gate center time	Low moment: 5.5 us High moment: 12.5 us
Last gate center time	Low moment: 25.0 us High moment: 350.0 us
Batteries	Li-Ion 14.4 V and 12.0V
Time of continuous operation	~2 hrs
Weight, incl. batteries and carrier system	Transmitter: 15 kg Receiver: 10 kg

Table 1. The table shows key specifications for the TEM2Go transmitter and receivers.

The TEM2Go system is operated from the TEMcompany iOS/Android app. The app makes the operation of the instrument extremely easy and does not require special skills from the operator. The app comes preloaded with a measurement script for either 50 or 60 Hz powerline operation. The app displays key parameters such as output current, temperature of the electronics, power level of the battery etc. It also displays the raw stacked transients. With Premium functionality enabled it shows real-time inverted models.

The distance between the person with the transmitter and the person with the receiver is determined by a special device mounted in the transmitter box and in the receiver pole. The distance must be a minimum of 15 meters, and it is not recommended to be larger than 20 m. If the distance becomes below 15 meters or more than 20 m the operators are warned by a sound signal.

The transmitter and receiver coils need to be close to horizontal while measuring. The coil angles can easily be adjusted by straps attached to the

backpack frame to adjust for the operator's height and walking styles.

Data is organized in a project and a project can have several lines. A new line is initiated with a simple tap on the screen.

The app has map functionality, data is displayed as it is measured and with Premium functionality, data is also inverted and displayed in a section view. This is illustrated in Figure 3.

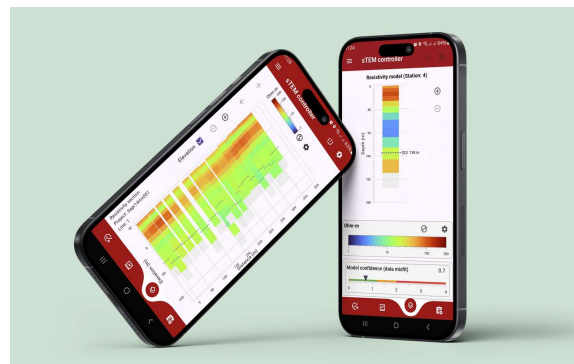

Figure 3 The figure shows the iOS/Android app with a single model and a cross section. This functionality is enabled with a Premium license.

3. Comparing TEM2Go and ERT

The TEM2Go instrument has been extensively tested and verified on the Danish National Test site for TEM instruments. All TEMcompany instruments, tTEM and sTEM, are verified on the site. SkyTEM Surveys also verifies its SkyTEM system on the site. Verifying the instruments on this site with well-determined geology means that they will always give the same model if the resolution capabilities and the footprint of the systems are taken into consideration.

The test site model consists of a thin top clay-dominated till layer, followed by a more resistive glacial sand layer, a till, and finally a low-resistivity tertiary clay layer.

An overview map of the test site is shown in Figure 4. The figure shows the test site with the red dot in

the middle and the test line used to verify systems measuring continuously along profiles.



Figure 4 The map shows the National Danish Test site. Black dots: Aarhus University WalkTEM 40x40 m central coil measurement, 2010. Red line: ERT profile, 700 m long, 5 m electrode spacing, standard gradient protocol, 2023. Yellow dots: TEM2Go, 10 m sounding spacing, 2025. The central dot in the middle is the test site, while the dots along the line are the test line. Reference: Test-site calibration and validation of airborne and ground-based TEM systems. N Foged, E Auken, AV Christensen, KI Sørensen - Geophysics, 2013

Figure 5 shows a comparison between the 40x40 m soundings and the TEM2Go soundings. Only the leftmost 500 m of the test line is shown. An excellent agreement between the 2010 40x40m dataset and the TEM2Go dataset is seen. The layer boundaries and resistivities of the units seem to match very well. The depth of Investigation (DOI) for the TEM2Go system is impressive, 70 – 80 m, though decreasing to the left because of noise from a nearby power line.

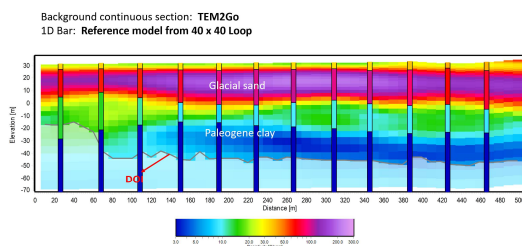

Figure 5 The figure shows a comparison between the 40 x 40 m soundings and the TEM2Go instrument. The soundings are shown with bars while the background is the TEM2Go model. The DOI for the TEM2Go system is between 70 and 80 m.

Figure 6 shows a comparison between the ERT and the TEM2Go model. Considering the vastly different footprints of the systems, ERT elongated banana shapes and TEM2Go close to circular, the sections compare quite good with all geological units being at the right depths and with similar resistivities. However, going into detail, there are some significant differences. a) The DOI for the TEM2Go is 70 – 80 m throughout the section, while the DOI for the ERT decreases to less than 30 m at the ends and only reaches full depth of 70 m in the central part of the section. b) The ERT has a few meters thick resistive layer at the surface, which is not resolved in the TEM2Go. The TEM2Go averages the first few meters into one layer with one average resistivity. c) In the deeper part of the section, the TEM2Go resolves the lower till and tertiary clay layer much better than the ERT. This is expected as ERT has a low sensitivity to layers with decreasing resistivity, while such a sequence does not affect the sensitivity of the TEM2Go.

TEM2Go system built on a light, carry-on professional backpack frame, has a significantly higher production rate than a heavy ERT system involving cable drums, steel electrodes, and car batteries for power. It takes 10 – 12 minutes for two people to walk a line, compared to 5 – 6 hours for the same people, using considerably more effort to measure an ERT line.

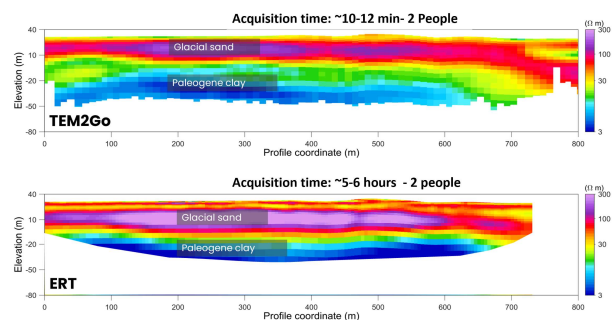

Figure 6 The figure shows a comparison between the TEM2Go models (top) and the ERT line. The TEM2Go line is 800 m long and took 10 - 12 minutes for two people to measure, while the ERT line is a bit more than 700 m, and it took 2 people 5 – 6 hours to measure.

The ERT line was measured during a wet period when maintaining a low contact resistance was not a problem. Had the same line been measured in the dry season, considerable effort would have been spent on pouring water on the electrodes and hammering them deep into the ground to obtain a low contact resistance and hence an acceptable signal-to-noise ratio. In comparison, the TEM2Go is not dependent on the surface conditions, whether they are wet or dry.

4. Extended support and instrument

Extended support

Access to extended support is offered by the expert Customer support team at TEMcompany. The team offers almost unlimited support for survey design, data quality assessment and data processing.

The extended support comes with a subscription that is renewed annually. Many customers sign up for extended support for the first year and after managing the measurement process by themselves.

App premium functionality

The TEM2Go instrument is designed for future upgrades and can be customized in various ways. It always comes with a software package providing basic functionality and the export of data to a Windows PC for processing.

Premium functionality is offered on a yearly subscription basis. With this subscription, several features are unlocked in the IOS/Android app. Premium functionality also comes with a free Windows app for displaying models in cross sections on a PC.

The premium functionalities are:

- Data is processed and inverted in real-time. The model of the subsurface geological layers is displayed at every 10 m in a cross-section view (Figure 3) and the position of the model is shown on the map.

- The DOI is calculated together with the quality of the data fit. These parameters are shown in the cross section.
- The accumulated station stack size for every 10 m is shown in the app.
- The individual transients are gated using non-square gates, also known as tapered gates. Tapered gates increase the signal-to-noise ratio by up to a factor of 2.
- Several other features in the app are unlocked. These include notes and pictures of the site.
- A free viewer for displaying the measured data on cross sections and maps is supplied. This viewer runs in Windows.

5. External processing software

Data collected by the TEM2Go instrument can be processed and inverted in a special design software. TEMcompany has decided to support data formats compatible with the Sequent software package Workbench. This software and functionality are described on the Sequent web page (<https://www.seequent.com/products-solutions/ags-workbench/>)

6. Document change log

Date	Change
20250328	Document created (Esben Auken)
20250417	Section on comparison of ERT and TEM2Go added (Esben Auken)

7. Detailed specifications

The following is a list of all technical specifications for the TEM2Go system. All numbers are for 50 Hz powerline frequency.

Definitions and abbreviations

LM	Transmitter low output current
HM	Transmitter high output current
Tx	Transmitter
Rx	Receiver
L, W, H	Length, Width and Height
Amp	Ampere
Amph	Ampere hours
V	Volt
Wh	Watt hours
°C	Degree Celsius
m	Meter
cm	Centimeter (10^{-2} m)
mm	Milli meter (10^{-3} m)
kg	Kilogram
hrs	Hours
Hz	Hertz
MHz	Mega Hertz (10^6 Hertz)
ms	Milliseconds (10^{-3} seconds)
Ohm	Resistance
us	Microseconds (10^{-6} seconds)

Transmitter platform

Item	Value
Dual moment	Yes
LM current	1 Amp
HM current	10 Amp
Nominal LM repetition rate (transients per second), number of transients in one raw stack	2500 Hz, 500 transients
Nominal HM repetition rate (transients per second), number of transients in one raw stack	1250 Hz, 1000 transients
Real-time processing and inversion	Yes
Onboard computer	Intel NUC or Industrial SBC

Internal RAM	8 GB or more
Storage capacity	SSD or eMMC 128 GB or more
Operating system	Linux (>6.8)
I/O interface	Mesh Wi-Fi
GPS receiver	Built-in GPS with SBAS
GPS antenna	On pole
Tx coil options	0.65 m x 0.65 m
Internal damping resistor	70 Ohm
Waveform recording	Pre recorded
Control app	iOS, Android
Pulse on / off times	Pre-defined
LM On-time/Off-time	50%/50%
HM On-time/Off-time	40%/60%
Cooling	Passive
Service and upgrades	Via internet
IP rating	ABS, IP65
Power 14.4V, 99.8 Wh	1 Li Ion battery
Dimensions	36 x 16 x 27 cm
Weight	5.2 kg
Operating temperature	-20 °C to +50 °C

Receiver platform

Item	Value
Sample rate	4 MHz
Dynamic range	>24 bit
Onboard computer	ARM processor integrated with FPGA
Internal RAM	1 GB or more
Storage capacity	eMMC 8 GB
Operating system	Linux (>5.15)
I/O interface	Mesh Wi-Fi
GPS receiver	Built-in GPS with SBAS
GPS antenna	On pole
Service and upgrades	Via internet
Bandwidth	~1 MHz
Nominal number of gates	20
Logarithmic sampled number of gates per decade	10

Nominal first and last gate center time	5.5 us –350 us
Max number of raw gates	1024
Tapered gating	Yes
Nominal sounding distance	10 m
Number of receiver channels	1
Accumulated station stack	Yes
Distance measurement to receiver	UWB accuracy 20 cm
IP rating	ABS, IP67
Power 12V 36.8 Wh	1 Li Ion battery
Dimensions	13 x 13 x 37 cm
Weight	2 kg
Operating temperature	-20 °C to +50 °C

Transmitter Coil

Item	Value
Dimension	0.65 cm x 0.65 cm
Number of turns	4
Effective area	1.7 m ²
Wire thickness	4 mm ²
Weight	2.5 kg
IP rating	ABS, IP67

Receiver Coil

Item	Value
Dimensions	0.65 cm x 0.65 cm
Type	Air core, shielded
Number of turns	53
Effective area	22 m ²
Bandwidth	~350 kHz
Amplification	21
Weight	3.5 kg
IP rating	ABS, IP67

Battery charging suitcase

Item	Rx battery	Tx battery
Charging capacity	12.0 V battery	14.4 V battery
Time to charge	2.5 hrs	2.5 hrs
Weight	2.0 kg	

Backpack carrier system

Item	Rx	Tx
Size	40 x 60 cm	
Carrier system	Professional light weight	
Weight	5.5 kg each	
Total weight of carriers including coils and instruments	10 kg	15 kg

Weight and dimensions for transport

Item	Weight	Dimensions
Transport box 1	35 kg	80 cm x 60 cm x 45 cm
Transport box 2	9 kg	70 cm x 78 cm x 26 cm